

STEALTH750

3/4 HP CONTINUOUS FEED FOOD WASTE DISPOSER

SPECIFICATION SHEET

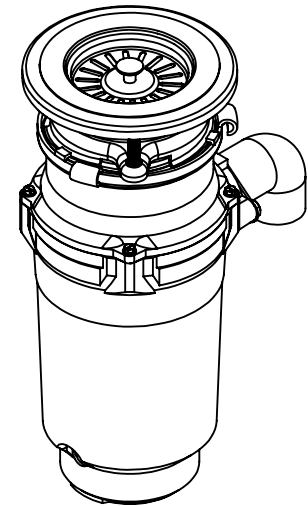
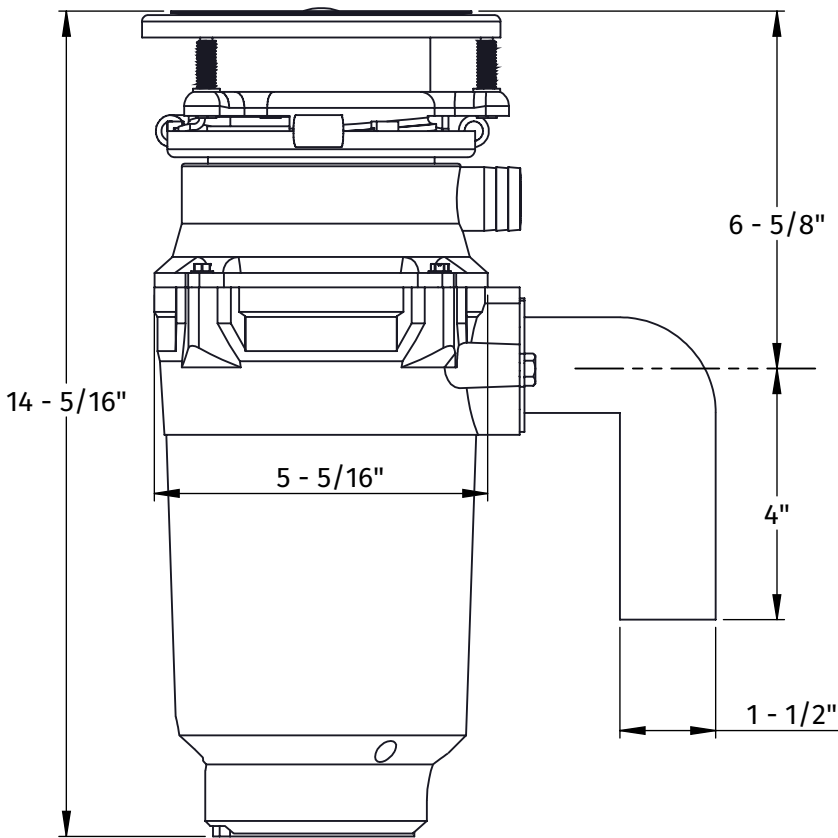

SPECIFICATIONS

HP	3/4
Motor Type	Permanent Magnet
Feed	Continuous
Volts	110V
Frequency	50/60 Hz
Wattage	550 W
Amperage	5.0A
Motor Speed	3600 RPM
Hopper Capacity	29 oz
Balance Level	G 0.4
Turntable	Stainless Steel
Grind Rings	Stainless Steel
Sink Flange	Stainless Steel
Stopper	Stainless Steel
Drain Elbow	ABS
Bearings	Permanently Lubricated, Sleeve Type
Manual Reset Protector	Protection for Overload & Temp
Shipping Weight	11.5 lb

FEATURES:

- Permanent Magnet High RPM Means High Torque & Fewer Jams
- Removable Splash Guard
- Stainless Steel Turntable & Grind Rings (Compared to Competitor's Cold-Rolled or Galvanized Steel)
- Factory Installed Power Cord with Plug
- Safe for Properly Sized Septic Tanks
- 3-Bolt Mounting System

WARRANTY

THE 3/4 HP MOUNTAIN PERFECT GRIND WASTE DISPOSER COMES WITH A LIFETIME WARRANTY AGAINST ANY MECHANICAL OR MATERIAL DEFECT. IN ADDITION TO THE ABOVE WARRANTY, ALL PERFECT GRIND DISPOSERS COME WITH A LIFETIME WARRANTY AGAINST CORROSION. LABOR NOT INCLUDED.