

PROSELECT 1

1/3 HP CONTINUOUS FEED FOOD WASTE DISPOSER

SPECIFICATION SHEET

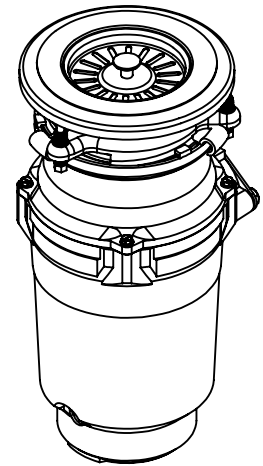
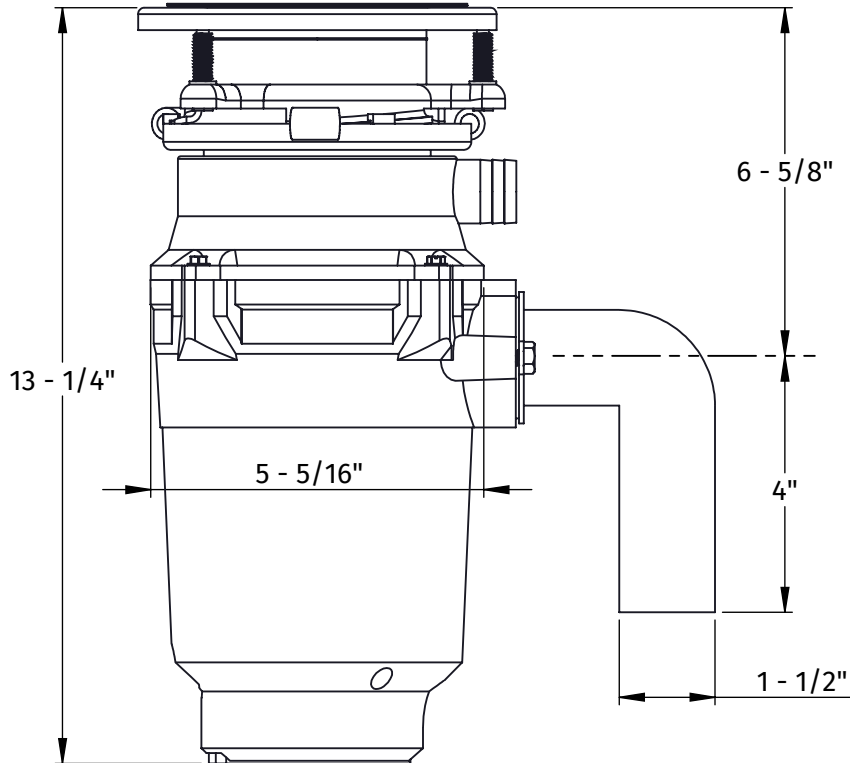

SPECIFICATIONS

HP	1/3
Motor Type	Permanent Magnet
Feed	Continuous
Volts	110V
Frequency	50/60 Hz
Wattage	250 W
Amperage	2.25A
Motor Speed	2800 RPM
Hopper Capacity	29 oz
Balance Level	G 0.4
Turntable	Stainless Steel
Grind Rings	Stainless Steel
Sink Flange	Stainless Steel
Stopper	Stainless Steel
Drain Elbow	ABS
Bearings	Permanently Lubricated, Sleeve Type
Manual Reset Protector	Protection for Overload & Temp
Shipping Weight	9.2 lb

FEATURES:

- Permanent Magnet High RPM Means High Torque & Fewer Jams
- Removeable Splash Guard
- Stainless Steel Turntable & Grind Rings (Compared to Competitor's Cold-Rolled or Galvanized Steel)
- Factory Installed Power Cord with Plug
- Safe for Properly Sized Septic Tanks
- 3-Bolt Mounting System

WARRANTY

THE 1/3 HP MOUNTAIN PERECT GRIND WASTE DISPOSER COMES WITH A 3-YEAR REPLACEMENT WARRANTY AGAINST ANY MECHANICAL OR MATERIAL DEFECT. IN ADDITION TO THE ABOVE WARRANTY, ALL PERFECT GRIND DISPOSERS COME WITH A LIFETIME WARRANTY AGAINST CORROSION. LABOR NOT INCLUDED.