

PHANTOM1

1 HP BLDC FOOD WASTE DISPOSER SPECIFICATION SHEET

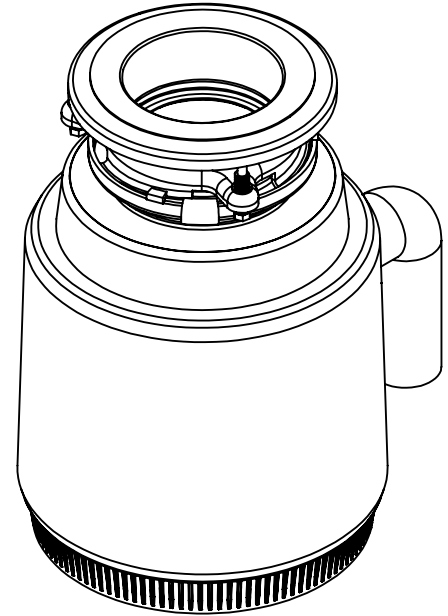
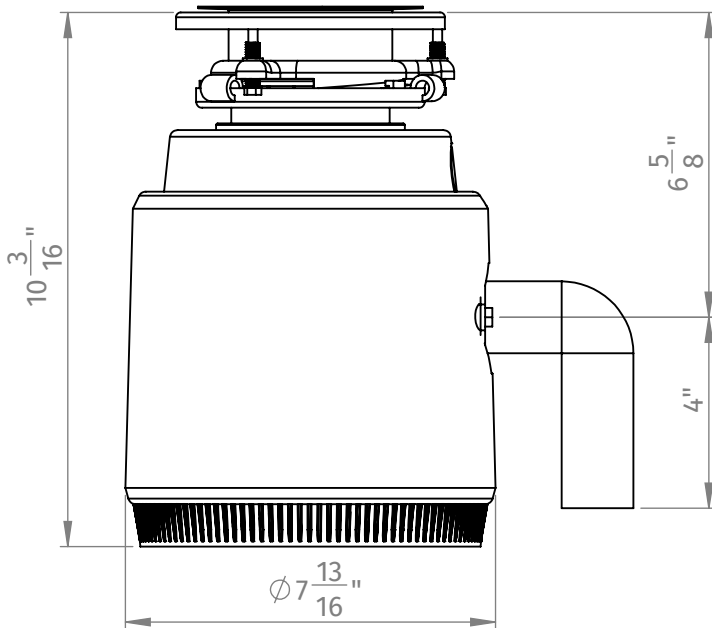

FEATURES:

- Brushless Motor Provides Close to No Noise
- Auto Unjamming Feature Rotates the Motor in the Opposite Direction
- Self Shut Down if Disposer is Left On Without Load Detected Initially
- Removable Splash Guard
- Stainless Steel Turntable & Grind Rings (Compared to Competitor's Cold-Rolled or Galvanized Steel)
- Safe for Properly Sized Septic Tanks
- 3-Bolt Mounting System

WARRANTY

THE PHANTOM1 WASTE DISPOSER COMES WITH A LIFETIME WARRANTY AGAINST ANY MECHANICAL OR MATERIAL DEFECT. IN ADDITION TO THE ABOVE WARRANTY, ALL PERFECT GRIND DISPOSERS COME WITH A LIFETIME WARRANTY AGAINST CORROSION. LABOR NOT INCLUDED.

HP	1
Motor Type	Brushless
Feed	Adaptive
Volts	110V
Frequency	50/60 Hz
Wattage	550
Amperage	1.8
Motor Speed	1600/3400RPM
Hopper Capacity	1500ml
Balance Level	>50mg
Turntable	Stainless Steel
Grind Rings	Stainless Steel
Sink Flange	Stainless Steel
Stopper	Stainless Steel
Drain Elbow	ABS
Bearings	Permanently Lubricated, Sleeve Type
Manual Reset Protector	Protection for Overload & Temp
Shipping Weight	11.8 lbs