

# MT250

## CUP RINSER - STAINLESS STEEL BODY WITH COVER

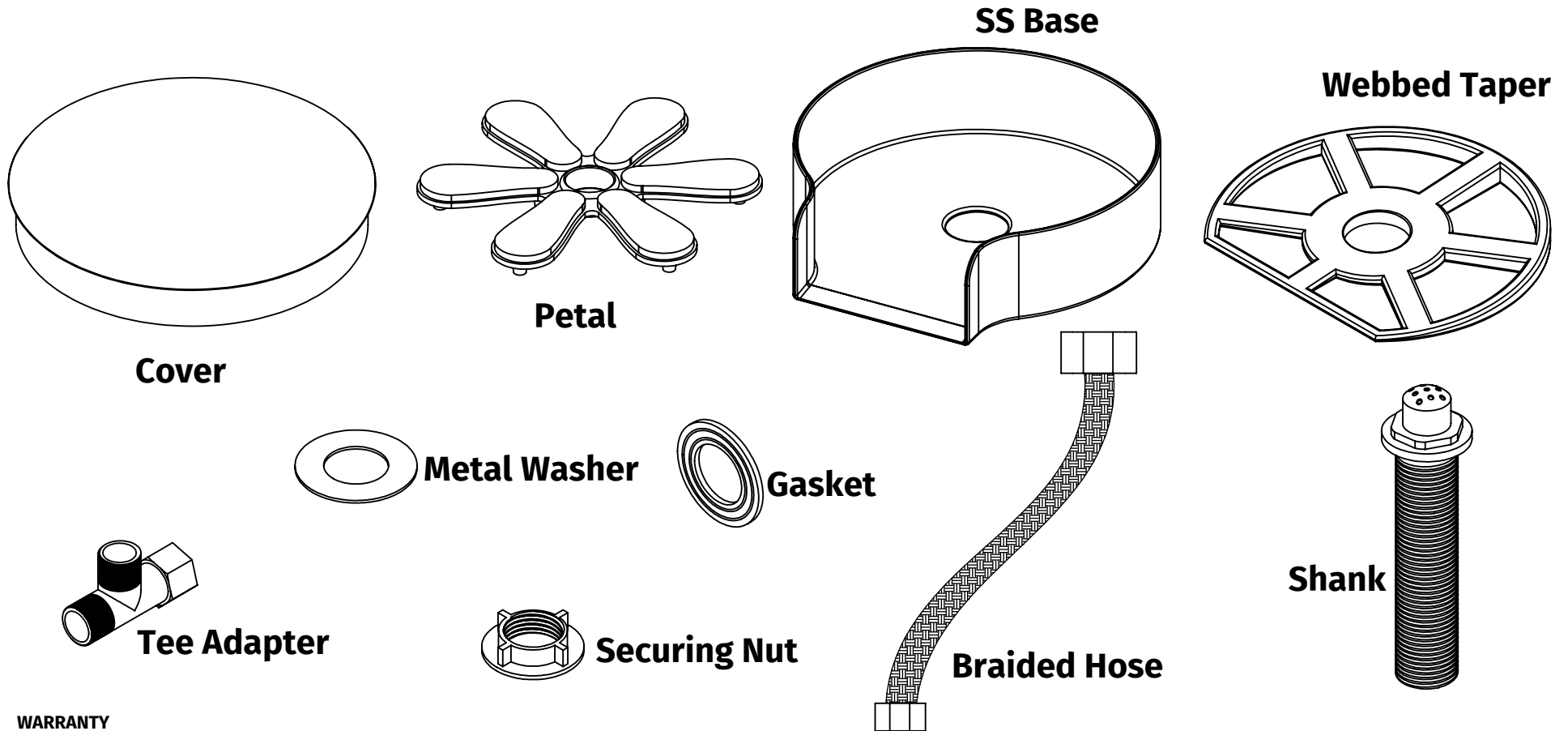

### Parts Provided



#### WARRANTY

FOR WARRANTY INFO PLEASE VISIT [WWW.MOUNTAINPLUMBING.COM/PAGE/RESOURCES/WARRANTY](http://WWW.MOUNTAINPLUMBING.COM/PAGE/RESOURCES/WARRANTY)

#### FINISH CARE & MAINTENANCE

NEVER USE ANY HARSH ALKALI, ACID BASED DETERGENTS OR CLEANERS SUCH AS SOFT SCRUB®, SCRUBBING BUBBLES® OR COMET® TO CLEAN. DO NOT USE BRILLO® OR SCOTCH BRITE® PADS. THESE WILL ALL HARM THE FINISH. TO CLEAN, USE ONLY A DAMP SOFT CLOTH AND WIPE GENTLY. STANDARD WINDEX® CAN ALSO BE USED SPARINGLY. IT IS NOT NECESSARY TO WIPE HARD TO REMOVE SPOTS. TO MAINTAIN THE FINISH, WIPE WITH A SOFT DRY CLOTH AFTER USE. AN OCCASIONAL COAT OF PURE CARNAUBA WAX WITHOUT CLEANERS WILL HELP PROTECT THE FINISH.

SPECIFICATIONS SUBJECT TO CHANGE WITHOUT NOTICE  
[www.mountainplumbing.com](http://www.mountainplumbing.com) 888-222-9140 fax 972-456-2719

# MT250

## CUP RINSER - STAINLESS STEEL BODY WITH COVER

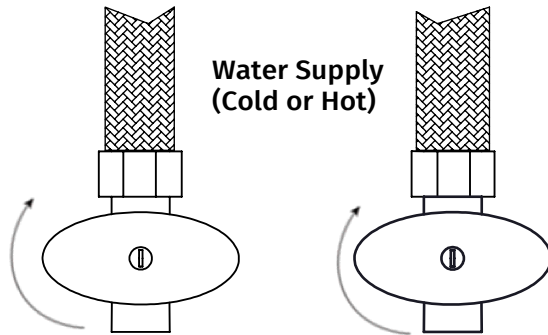

**1.DECIDE WHETHER TO USE HOT OR COLD WATER FOR YOUR NEW CUP RINSER**

**2.TURN OFF BOTH HOT AND COLD WATER SUPPLIES UNDER THE SINK AND TURN WATER FAUCET ON AND OFF FOR CONFIRMATION THAT WATER SUPPLY IS OFF**

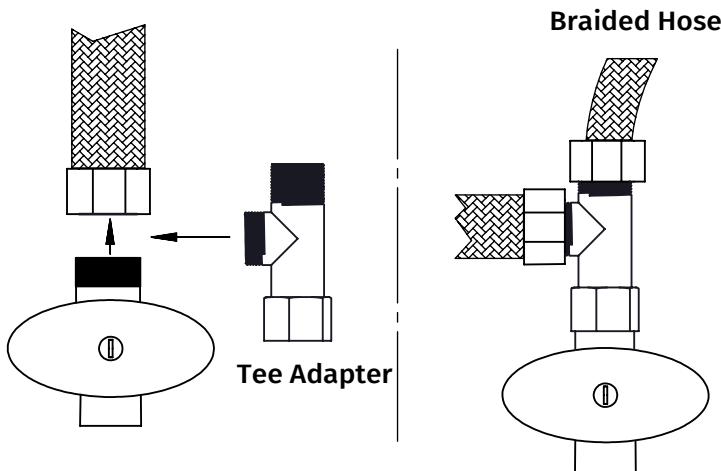

**3.UNSCREW CURRENT SUPPLY CONNECTION HOSE AND SECURELY SCREW IN SUPPLIED TEE ADAPTER**

**4.SCREW IN SUPPLY HOSE TO TEE ADAPTER REMOVED IN LAST STEP**

**5.SCREW IN AND SECURE BRAIDED HOSE PROVIDED TO TEE ADAPTER**

### WARRANTY

FOR WARRANTY INFO PLEASE VISIT [WWW.MOUNTAINPLUMBING.COM/PAGE/RESOURCES/WARRANTY](http://WWW.MOUNTAINPLUMBING.COM/PAGE/RESOURCES/WARRANTY)

### FINISH CARE & MAINTENANCE

NEVER USE ANY HARSH ALKALI, ACID BASED DETERGENTS OR CLEANERS SUCH AS SOFT SCRUB®, SCRUBBING BUBBLES® OR COMET® TO CLEAN. DO NOT USE BRILLO® OR SCOTCH BRITE® PADS. THESE WILL ALL HARM THE FINISH. TO CLEAN, USE ONLY A DAMP SOFT CLOTH AND WIPE GENTLY. STANDARD WINDEX® CAN ALSO BE USED SPARINGLY. IT IS NOT NECESSARY TO WIPE HARD TO REMOVE SPOTS. TO MAINTAIN THE FINISH, WIPE WITH A SOFT DRY CLOTH AFTER USE. AN OCCASIONAL COAT OF PURE CARNAUBA WAX WITHOUT CLEANERS WILL HELP PROTECT THE FINISH.

SPECIFICATIONS SUBJECT TO CHANGE WITHOUT NOTICE  
[www.mountainplumbing.com](http://www.mountainplumbing.com) 888-222-9140 fax 972-456-2719

# MT250

## CUP RINSER - STAINLESS STEEL BODY WITH COVER

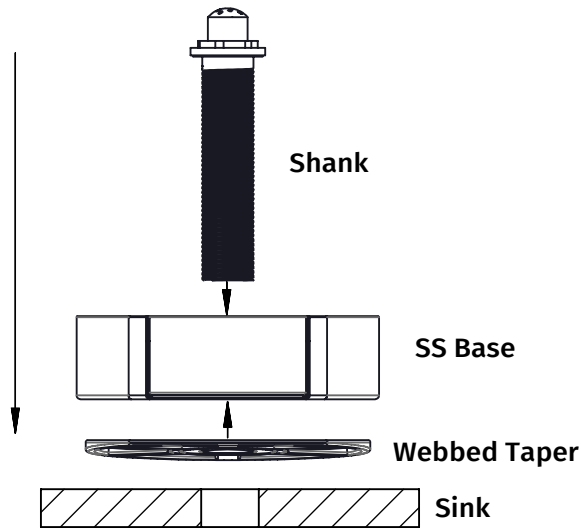

6.SLIDE SHANK THROUGH SS BASE AND WEBBED TAPER

7.SLIDE THIS ASSEMBLY THROUGH SINK HOLE

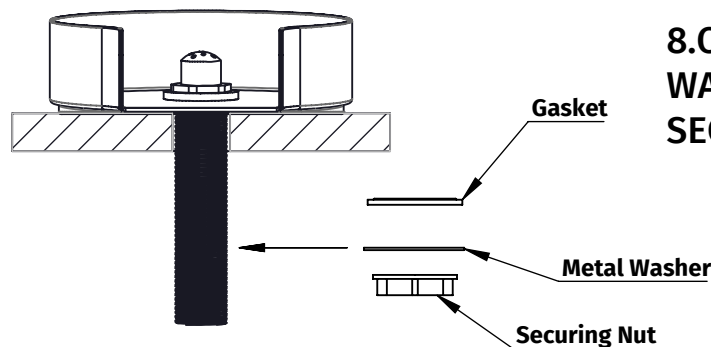

8.ONCE SHANK IS THROUGH SINK, SLIDE GASKET AND METAL WASHER THROUGH SHANK AND SECURE ASSEMBLY WITH SECURING NUT

### WARRANTY

FOR WARRANTY INFO PLEASE VISIT [WWW.MOUNTAINPLUMBING.COM/PAGE/RESOURCES/WARRANTY](http://WWW.MOUNTAINPLUMBING.COM/PAGE/RESOURCES/WARRANTY)

### FINISH CARE & MAINTENANCE

NEVER USE ANY HARSH ALKALI, ACID BASED DETERGENTS OR CLEANERS SUCH AS SOFT SCRUB®, SCRUBBING BUBBLES® OR COMET® TO CLEAN. DO NOT USE BRILLO® OR SCOTCH BRITE® PADS. THESE WILL ALL HARM THE FINISH. TO CLEAN, USE ONLY A DAMP SOFT CLOTH AND WIPE GENTLY. STANDARD WINDEX® CAN ALSO BE USED SPARINGLY. IT IS NOT NECESSARY TO WIPE HARD TO REMOVE SPOTS. TO MAINTAIN THE FINISH, WIPE WITH A SOFT DRY CLOTH AFTER USE. AN OCCASIONAL COAT OF PURE CARNAUBA WAX WITHOUT CLEANERS WILL HELP PROTECT THE FINISH.

SPECIFICATIONS SUBJECT TO CHANGE WITHOUT NOTICE  
[www.mountainplumbing.com](http://www.mountainplumbing.com) 888-222-9140 fax 972-456-2719

# MT250

## CUP RINSER - STAINLESS STEEL BODY WITH COVER

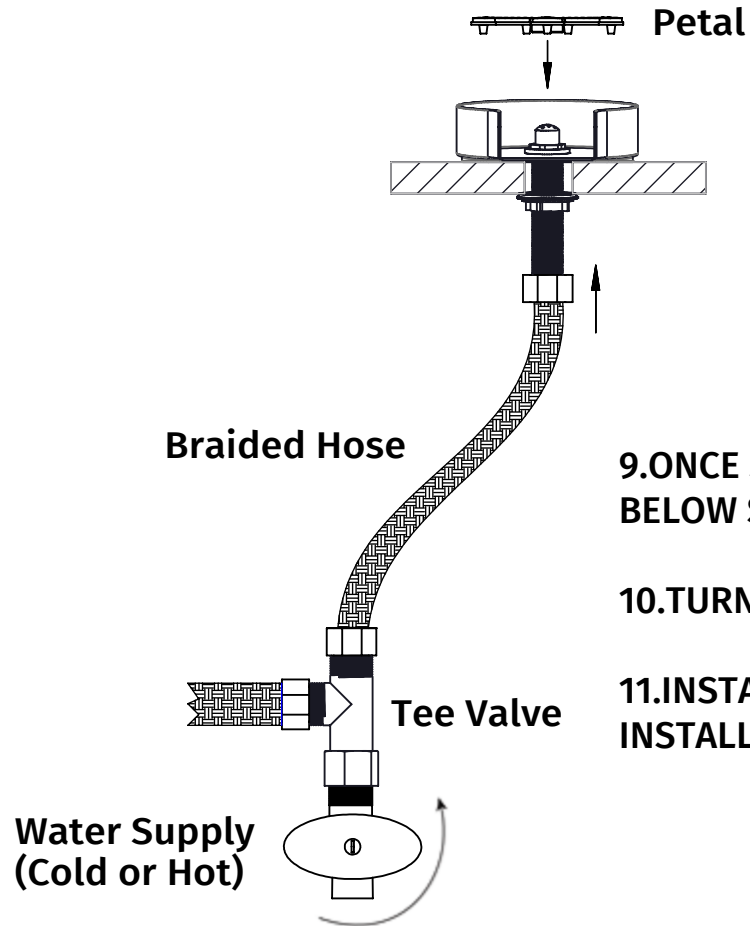

9. ONCE SECURED, SECURELY SCREW IN BRAIDED HOSE END TO SHANK BELOW SINK

10. TURN ON BOTH WATER SUPPLY VALVES AND CHECK FOR LEAKS

11. INSTALL PETAL ON SHANK NOZZLE AND TEST OUT TO FINISH INSTALLATION

### WARRANTY

FOR WARRANTY INFO PLEASE VISIT [WWW.MOUNTAINPLUMBING.COM/PAGE/RESOURCES/WARRANTY](http://WWW.MOUNTAINPLUMBING.COM/PAGE/RESOURCES/WARRANTY)

### FINISH CARE & MAINTENANCE

NEVER USE ANY HARSH ALKALI, ACID BASED DETERGENTS OR CLEANERS SUCH AS SOFT SCRUB®, SCRUBBING BUBBLES® OR COMET® TO CLEAN. DO NOT USE BRILLO® OR SCOTCH BRITE® PADS. THESE WILL ALL HARM THE FINISH. TO CLEAN, USE ONLY A DAMP SOFT CLOTH AND WIPE GENTLY. STANDARD WINDEX® CAN ALSO BE USED SPARINGLY. IT IS NOT NECESSARY TO WIPE HARD TO REMOVE SPOTS. TO MAINTAIN THE FINISH, WIPE WITH A SOFT DRY CLOTH AFTER USE. AN OCCASIONAL COAT OF PURE CARNAUBA WAX WITHOUT CLEANERS WILL HELP PROTECT THE FINISH.

SPECIFICATIONS SUBJECT TO CHANGE WITHOUT NOTICE  
[www.mountainplumbing.com](http://www.mountainplumbing.com) 888-222-9140 fax 972-456-2719