

MT1900-NL

SINGLE HANDLE HOT & COLD WATER DISPENSER FAUCET

INSTALLATION SHEET

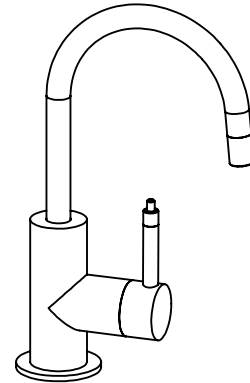
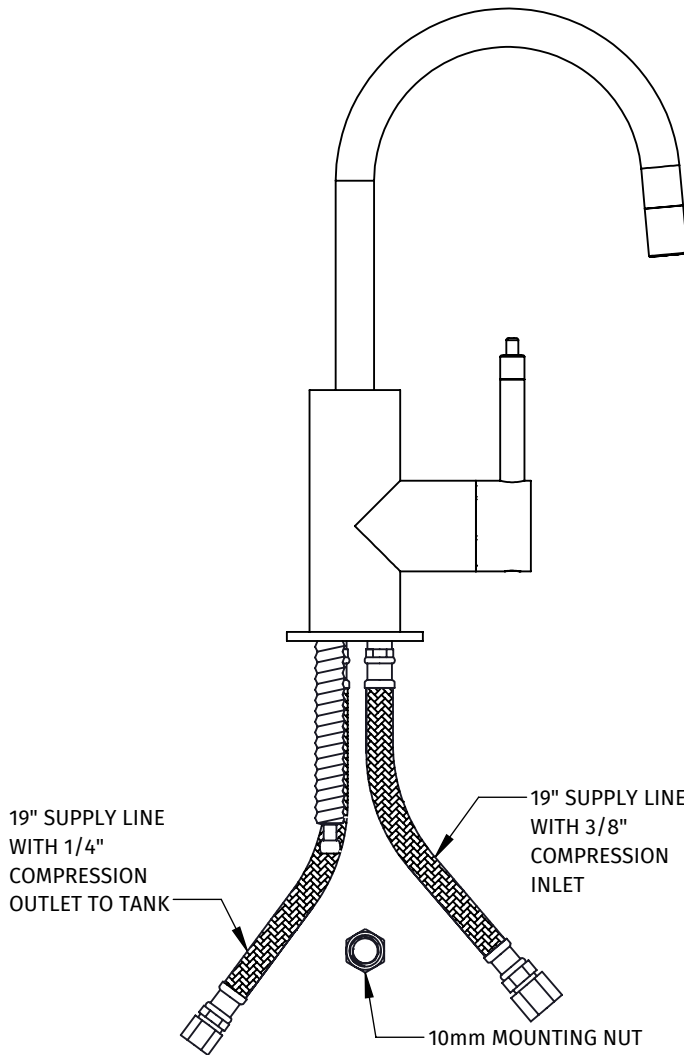

- REQUIRES LITTLE GOURMET® HEATING TANK MT641-3 (SOLD SEPARATELY)
- FITS MOUNTING HOLE FROM 1 - 1/8" TO 1 - 1/2" DIAMETER
- NSF 61 & NSF 372 CERTIFIED, Q ≤ 1
- WILL FIT DECK UP TO 2 1/4" THICK
- MOTION 25 C 90 degree CERAMIC CARTRIDGE (BF26028)
- HANDLE IS NOT SPRING-LOADED
- REVERSE OSMOSIS SAFE (OPTIONAL AIR GAP AG1800 SOLD SEPARATELY)
- INCLUDES CONNECTION HARDWARE AND 2 FT SILICONE HOSE TO CONNECT HOT TANK (PART # RKDW-HOSEKIT)
- COMPATIBLE WITH MT1250XL, MT660, AND MT662 FILTRATION SYSTEMS (SOLD SEPARATELY)



MEETS THE AMERICANS WITH DISABILITIES ACT GUIDE-LINES AND ANSI A117.1 ACCESSIBLE AND USABLE BUILDINGS AND FACILITIES - CHECK LOCAL CODES

WARRANTY

FOR WARRANTY INFO PLEASE VISIT WWW.MOUNTAINPLUMBING.COM/PAGE/RESOURCES/WARRANTY

FINISH CARE & MAINTENANCE

NEVER USE ANY HARSH ALKALI, ACID BASED DETERGENTS OR CLEANERS SUCH AS SOFT SCRUB®, SCRUBBING BUBBLES® OR COMET® TO CLEAN. DO NOT USE BRILLO® OR SCOTCH BRITE® PADS. THESE WILL ALL HARM THE FINISH. TO CLEAN, USE ONLY A DAMP SOFT CLOTH AND WIPE GENTLY. STANDARD WINDEX® CAN ALSO BE USED SPARINGLY. IT IS NOT NECESSARY TO WIPE HARD TO REMOVE SPOTS. TO MAINTAIN THE FINISH, WIPE WITH A SOFT DRY CLOTH AFTER USE. AN OCCASIONAL COAT OF PURE CARNAUBA WAX WITHOUT CLEANERS WILL HELP PROTECT THE FINISH.

SPECIFICATIONS SUBJECT TO CHANGE WITHOUT NOTICE

www.mountainplumbing.com 888-222-9140 fax 972-456-2719

Page 1

Form MT1900-NL inst sht

MT1900-NL REPLACEMENT PARTS

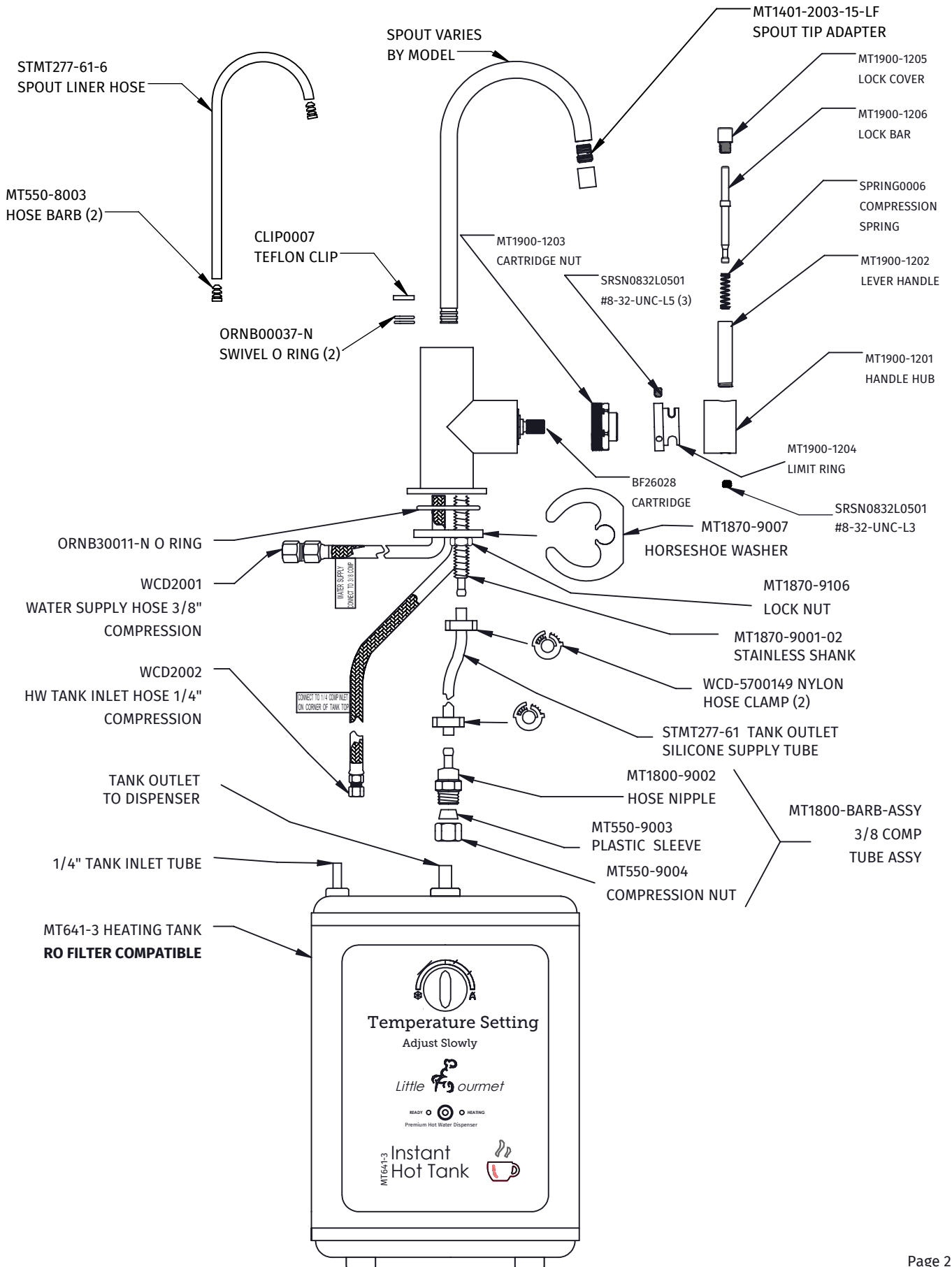

IMPORTANT PLEASE READ:

- ➔ **INSTALLATION MUST COMPLY WITH LOCAL PLUMBING CODES.**
- ➔ **READ THESE INSTRUCTIONS FOR THE DISPENSER AND MT641-3 HEATING TANK BEFORE PROCEEDING.**
- ➔ **DO NOT KINK FLEXIBLE SS HOSES. MAKE SURE THE TANK OUTLET SUPPLY TUBE HAS NO LOOPS OR LOW AREAS.**
- ➔ **TIGHTEN FITTINGS WITH AN ADJUSTABLE CRESCENT OR OPEN END WRENCH. NEVER USE A PIPE WRENCH.**
- ➔ **NEVER DISPENSE BOTH HOT AND COLD WATER AT THE SAME TIME.**
- ➔ **DISPENSER MAY OCCASIONALLY DRIP DURING INITIAL HEAT UP AND DURING USE WHEN TANK IS HEATING MORE WATER.**

1. MAKE SURE COUNTER HAS A \varnothing 1 1/8" MOUNTING HOLE (NO LARGER THAN \varnothing 1 1/2") AND COUNTER IS NO MORE THAN 2 1/4" THICK.
2. REMOVE LOCK NUT AND HORSESHOE WASHER FROM THE DISPENSER NIPPLE.
3. MAKE SURE ORING ORNB30011-N IS IN THE BOTTOM OF ESCUTCHEON. SLIDE THE MOUNTING HOSES THROUGH THE COUNTER.
4. PLACE THE HORSESHOE WASHER ON THE MOUNTING NIPPLE AND THREAD ON LOCK NUT. MAKE SURE DISPENSER IS ALIGNED PROPERLY AND THE HOT HANDLE IS ON THE LEFT. TIGHTEN THE LOCK NUT.
5. MAKE SURE THE HEATING TANK IS LOCATED SO THAT THE WCD2002 HW TANK HOSE CAN BE CONNECTED DIRECTLY TO THE HEATER WITHOUT ANY EXTENSIONS. **DO NOT REPLACE INCLUDED SILICONE TUBE WITH A TUBE NOT PROVIDED BY MOUNTAIN PLUMBING.**

INSTALL THE HEATING TANK PER THE INSTRUCTIONS SUPPLIED WITH THE HEATING TANK.

6. CONNECT WCD2001 SUPPLY HOSE TO AN INLET STOP OR SUPPLY VALVE. DO NOT CONNECT DIRECTLY TO A WATER SUPPLY WITHOUT A SHUTOFF VALVE. **FLUSH** ALL LINES BEFORE CONNECTING.
7. CONNECT THE WCD2002 1/4" COMPRESSION HOSE TO THE TANK INLET LOCATED IN THE RIGHT HAND BACK CORNER ON THE TOP OF THE TANK. SEE FIG 1.
8. INSTALL MT1800-BARB-ASSY 3/8" COMPRESSION TUBE ASSY ON TANK OUTLET TUBE. DO NOT OVER TIGHTEN.
9. SLIDE CLAMP WCD-5700149 ON THE TANK OUTLET SUPPLY TUBE AND PUSH TUBE ALL THE WAY UP ON THE MOUNTING NIPPLE BARB.
10. CHECK THE CORRECT POSITION AND LENGTH OF THE SILICONE HOSE SO THAT THERE ARE NO LOOPS OR LOW AREAS WHEN INSTALLED ON THE TANK. CUT THE HOSE IF REQUIRED, SLIP ON CLAMP WCD-5700149 THEN PUSH HOSE ON BARB END OF COMPRESSION TUBE ASSY. THEN SQUEEZE THE CLAMPS TO SECURE. DO NOT OVER TIGHTEN.
11. VERIFY ALL CONNECTIONS ARE TIGHT AND REFER TO TANK INSTRUCTIONS FOR INITIAL HEAT UP OF TANK.
12. **DO NOT PLUG IN HEATING TANK YET!** TURN ON WATER, OPEN HOT SIDE TO FILL TANK. TANK IS FULL WHEN WATER FLOWS FROM DISPENSER. CHECK FOR LEAKS.
13. PLUG IN TANK AND TURN CONTROL KNOB TO 3 O'CLOCK THEN WAIT 15 MINUTES FOR TANK TO HEAT. CHECK FOR LEAKS AGAIN THEN ADJUST TO THE TEMPERATURE DESIRED.

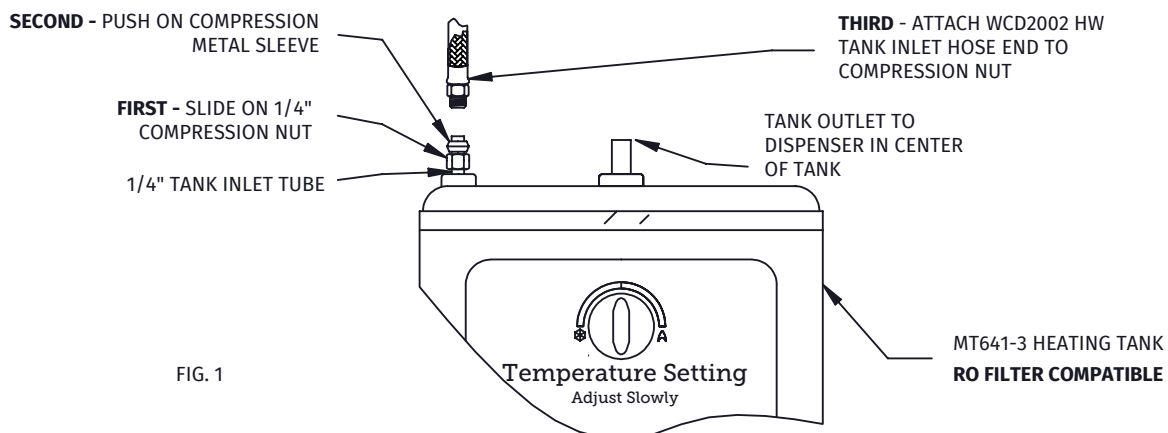

FIG. 1

FINISH CARE & MAINTENANCE

NEVER USE ANY HARSH ALKALI, ACID BASED DETERGENTS OR CLEANERS SUCH AS SOFT SCRUB®, SCRUBBING BUBBLES® OR COMET® TO CLEAN. DO **NOT** USE BRILLO® OR SCOTCH BRITE® PADS, AS THESE WILL ALL HARM THE FINISH.

TO CLEAN, USE ONLY A DAMP SOFT CLOTH AND WIPE USING A SOFT CLOTH. STANDARD WINDEX® CAN ALSO BE USED SPARINGLY. IT IS NOT NECESSARY TO WIPE HARD TO REMOVE SPOTS.

TO MAINTAIN THE FINISH, WIPE WITH A SOFT DRY CLOTH AFTER USE. AN OCCASIONAL COAT OF PURE CARNAUBA WAX WITHOUT CLEANERS WILL HELP PROTECT THE FINISH.

CAUTION

SIMILAR TO ANY WATER HEATER, THE HEATING TANK HAS A LIMITED LIFE AND AS A RESULT MAY EVENTUALLY LEAK. IT IS RECOMMENDED THAT REGULAR INSPECTIONS ARE PERFORMED ON THE HEATING TANK AND DISPENSER TO AVOID ANY PROPERTY DAMAGE. ADDITIONALLY, THE INSTALLATION OF A DRAIN PAN WITH DRAIN OR LEAK DETECTOR WILL ALSO HELP PROTECT AGAINST PROPERTY DAMAGE .

WARRANTY

FOR FULL WARRANTY INFORMATION PLEASE VISIT
WWW.MOUNTAINPLUMBING.COM/PAGE/RESOURCES/WARRANTY

