

# MT400U, MT500U

## DISHWASHER AIR GAP UNIT

### INSTALLATION INSTRUCTIONS



A McAlpine Company

# Mountain

Plumbing Products

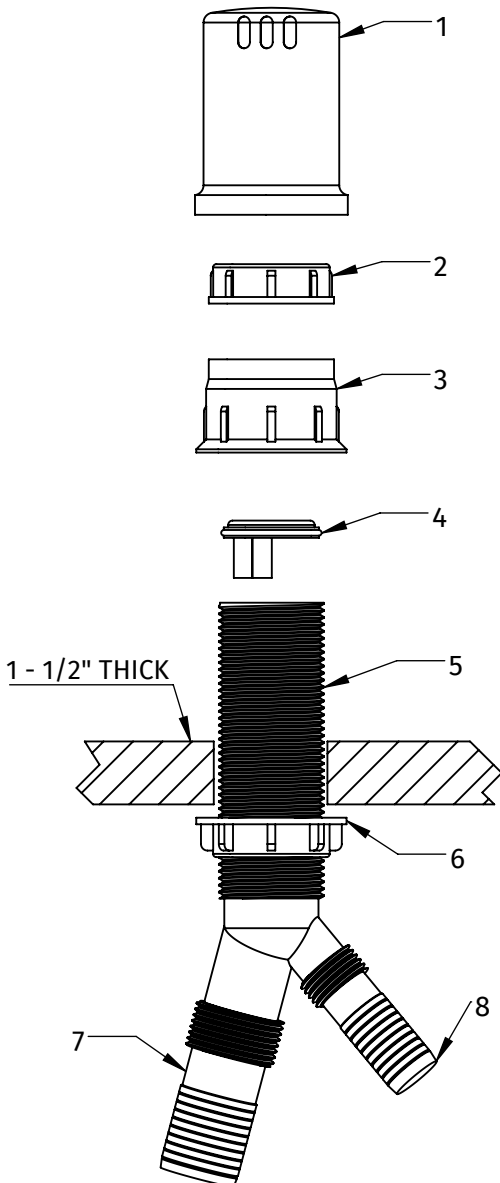

#### PREPARATION:

- REQUIRES MINIMUM  $\varnothing 1 - 3/8$ " HOLE IN SINK DECK
- FITS UP TO 1 - 1/2" THICK DECK

#### INSTALLATION STEPS:

1. REMOVE METAL COVER (1), NUT (2), AND COLLAR (3) FROM AIR GAP BODY (5). LOOSEN LOCK NUT (6) DOWNWARDS ALONG THE THREADED BODY.

**NOTE:** IT IS NOT NECESSARY TO REMOVE THE CAP (4) FROM THE AIR GAP BODY (5). HOWEVER, IF YOU DO REMOVE IT, TAKE CARE TO REINSERT THE CAP WITH THE ARROW ON TOP OF THE CAP (4) ALIGNED WITH THE NOTCH ON THE AIR GAP BODY (5). BOTH AIR TUBES SHOULD BE ON THE SAME SIDE AS THE OUTLET (7).

2. ATTACH HOSES AS FOLLOWS, USING SECURE CLAMPS:

- INLET HOSE FROM DISHWASHER CONNECTS TO SMALLER INLET NIPPLE (8)
- OUTLET HOSE TO DRAIN CONNECTS TO LARGER NIPPLE (7)

3. WITH HOSES ATTACHED, INSERT AIR GAP BODY (5) UP THROUGH HOLE IN SINK. PLACE COLLAR (3) OVER THREADED PORTION OF BODY AND SCREW NUT (2) FIRMLY INTO PLACE.

4. TIGHTEN LOCK NUT (6) FIRMLY AGAINST THE BOTTOM OF THE SINK DECK TO HOLD THE UNIT IN PLACE.

5. PLACE THE METAL COVER (1) OVER THE TOP OF THE ASSEMBLY.

#### WARRANTY

FOR WARRANTY INFO PLEASE VISIT [WWW.MOUNTAINPLUMBING.COM/PAGE/RESOURCES/WARRANTY](http://WWW.MOUNTAINPLUMBING.COM/PAGE/RESOURCES/WARRANTY)

#### FINISH CARE & MAINTENANCE

NEVER USE ANY HARSH ALKALI, ACID BASED DETERGENTS OR CLEANERS SUCH AS SOFT SCRUB®, SCRUBBING BUBBLES® OR COMET® TO CLEAN. DO NOT USE BRILLO® OR SCOTCH BRITE® PADS. THESE WILL ALL HARM THE FINISH. TO CLEAN, USE ONLY A DAMP SOFT CLOTH AND WIPE GENTLY. STANDARD WINDEX® CAN ALSO BE USED SPARINGLY. IT IS NOT NECESSARY TO WIPE HARD TO REMOVE SPOTS. TO MAINTAIN THE FINISH, WIPE WITH A SOFT DRY CLOTH AFTER USE. AN OCCASIONAL COAT OF PURE CARNAUBA WAX WITHOUT CLEANERS WILL HELP PROTECT THE FINISH.

SPECIFICATIONS SUBJECT TO CHANGE WITHOUT NOTICE